

Montageanleitung

LIGHT 032/030

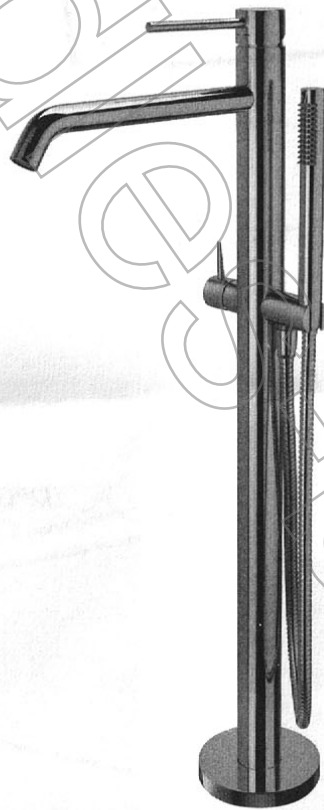

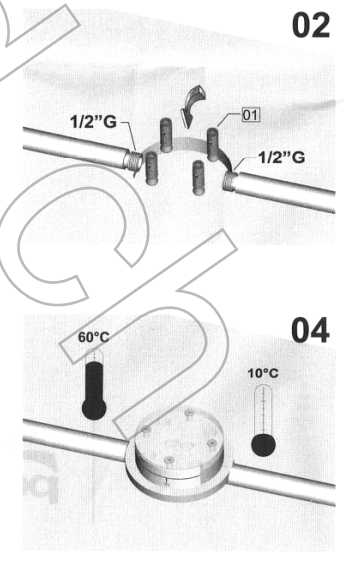
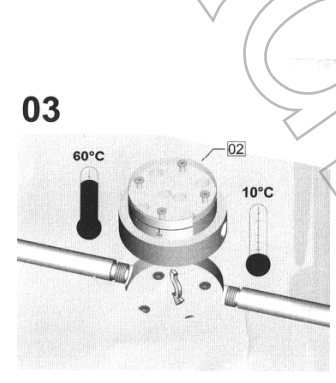
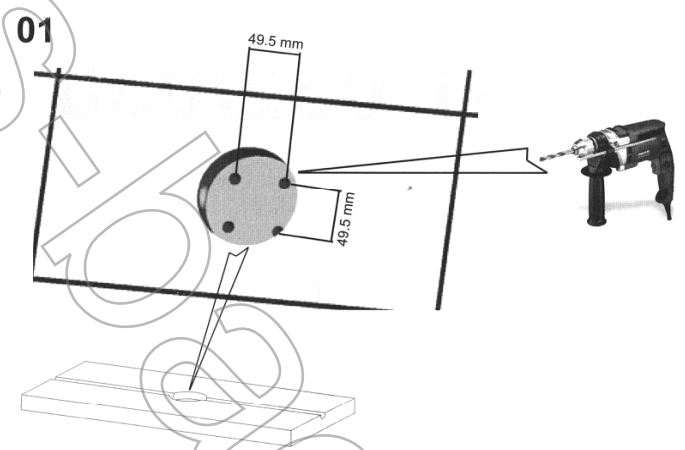
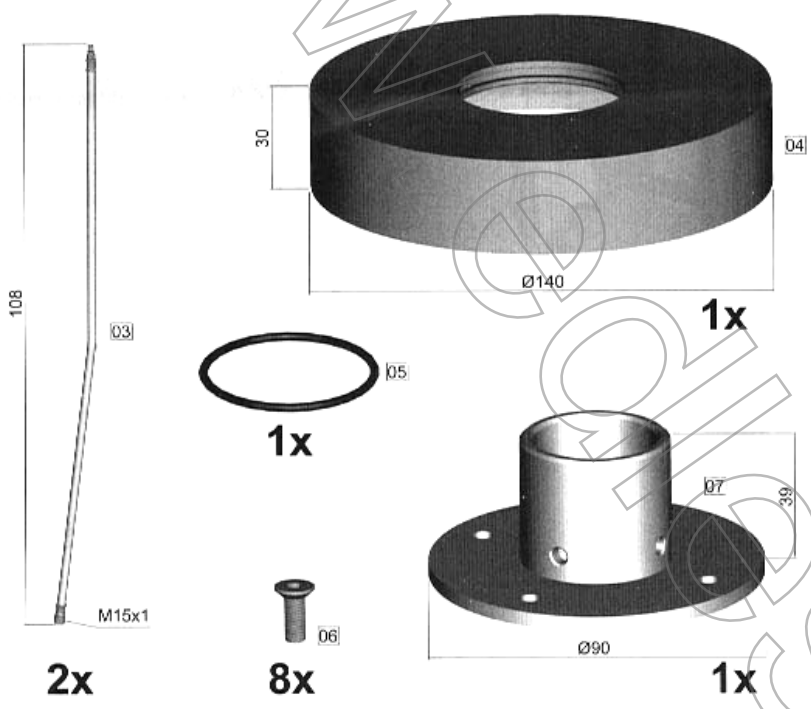
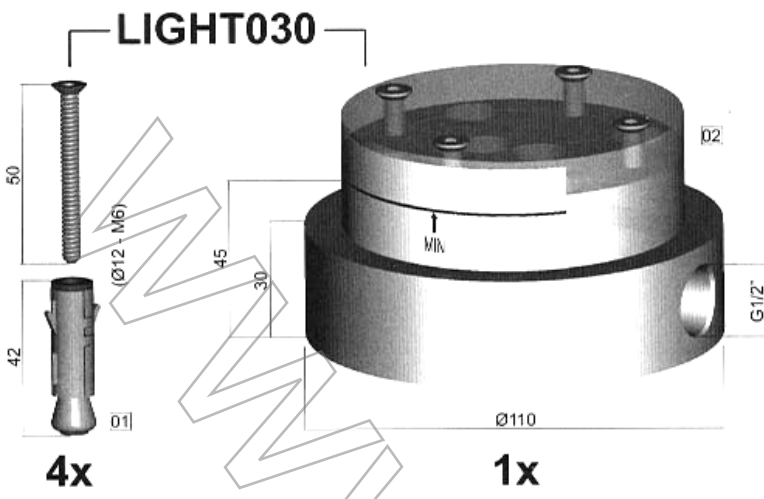

05

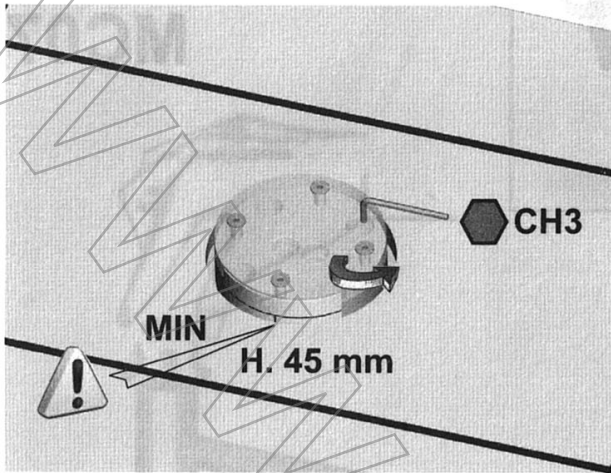

Die Montageplatte muss komplett horizontal eingebaut und mit Fließmörtel eingegossen werden.

Die Säule wird auf den Fuss geschraubt !

06

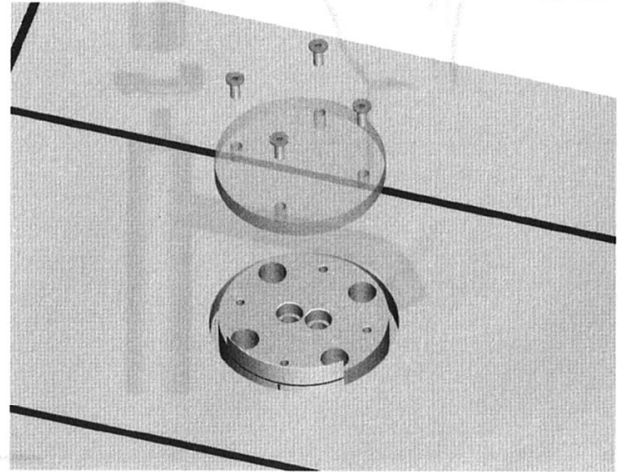

07

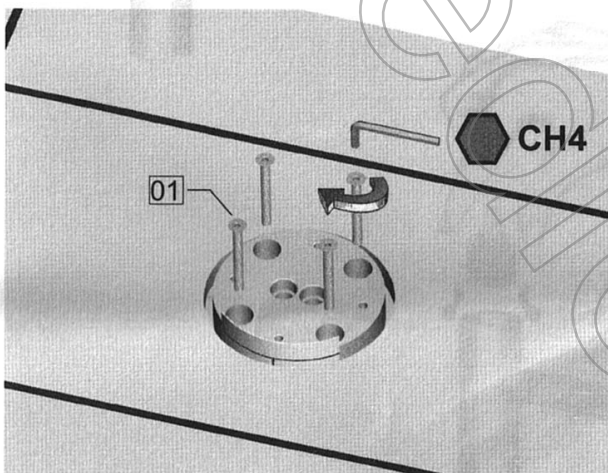

08

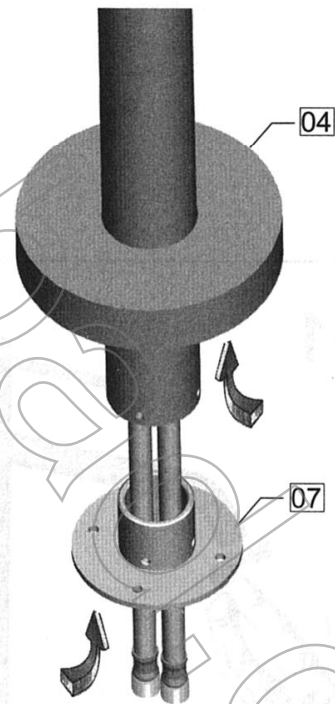

09

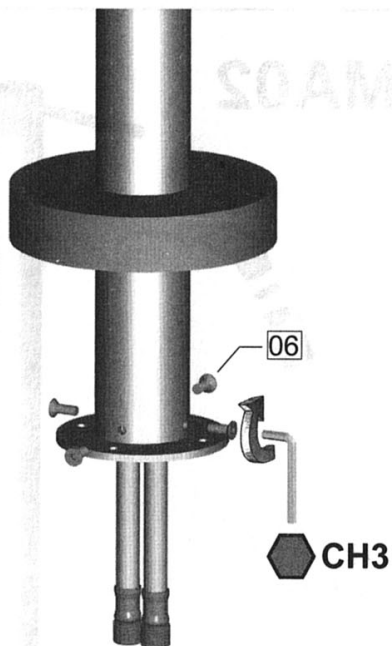

10

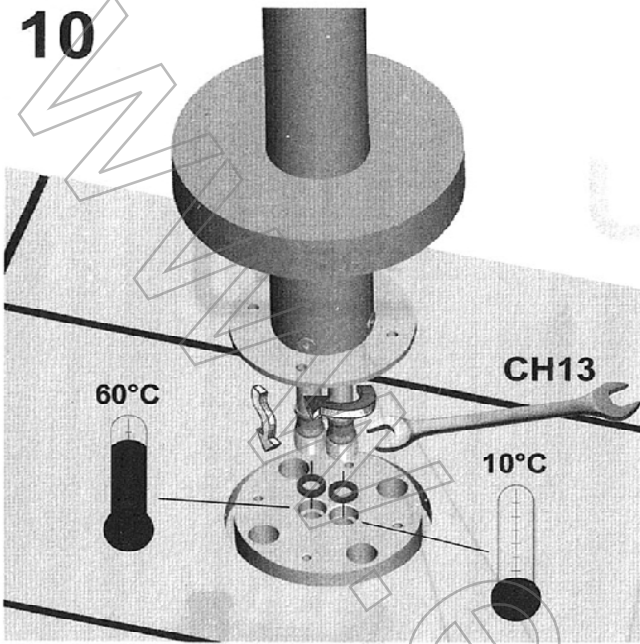

11

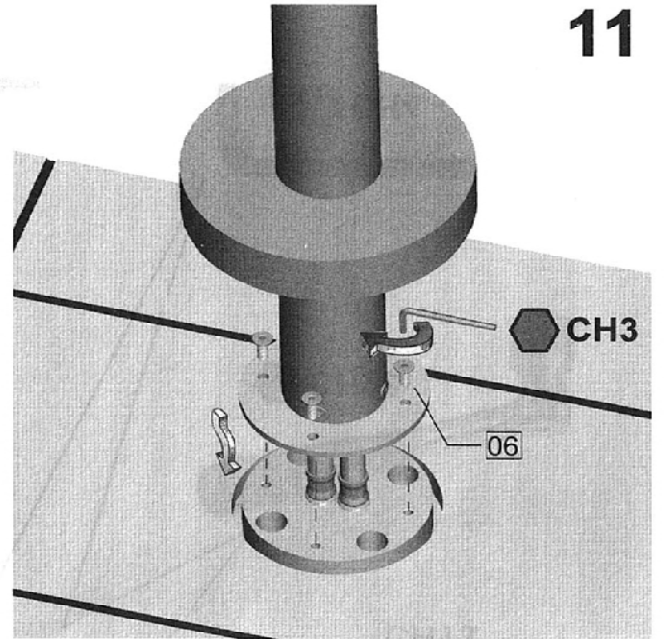

12

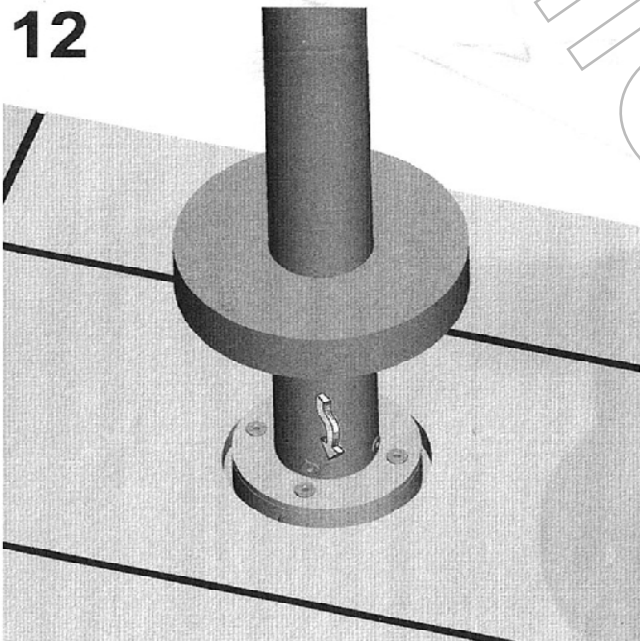

13

