

**mc bath**  
ANDROMEDA

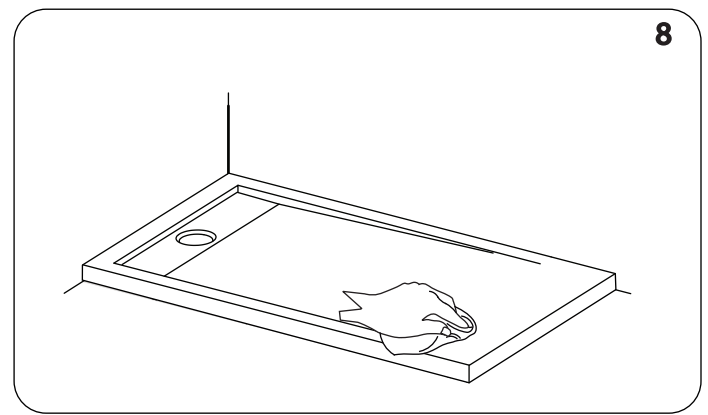
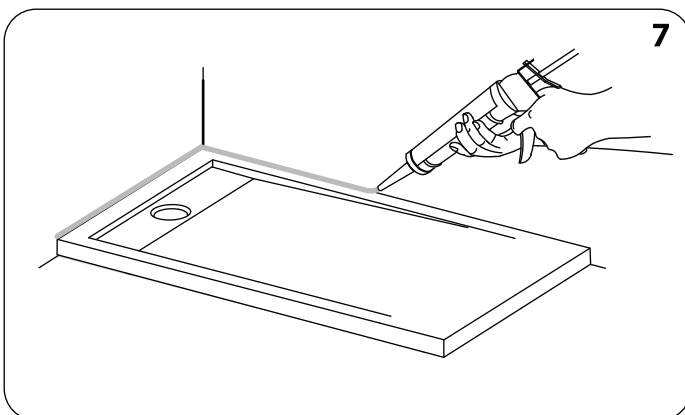
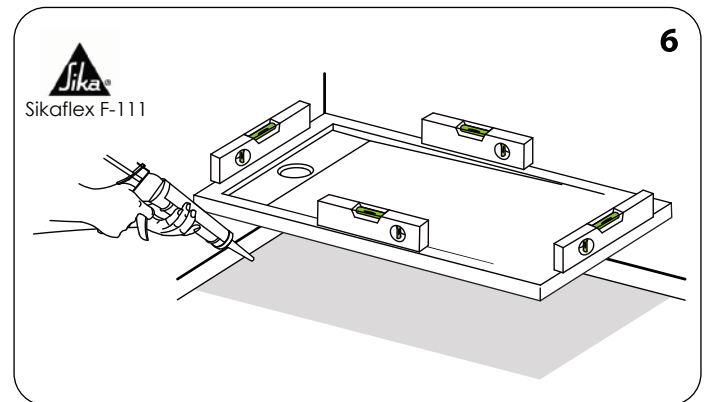
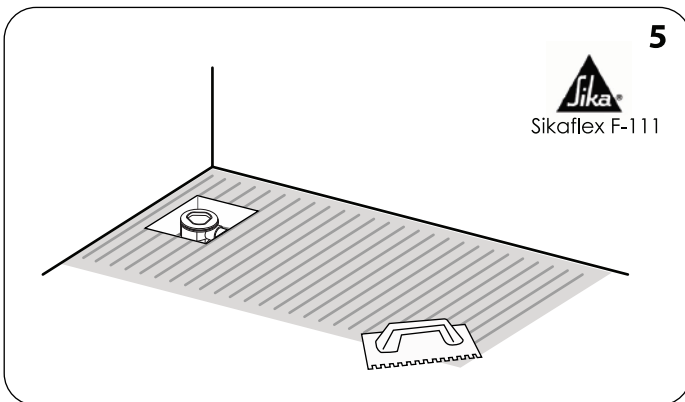
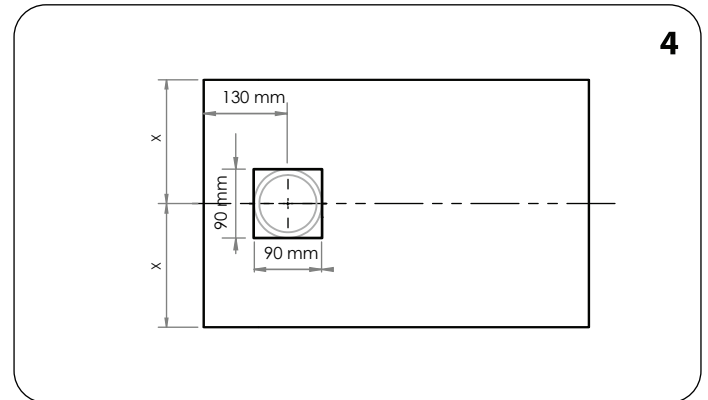
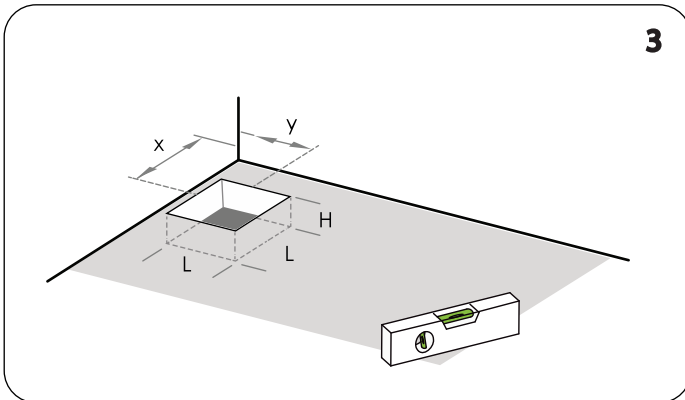
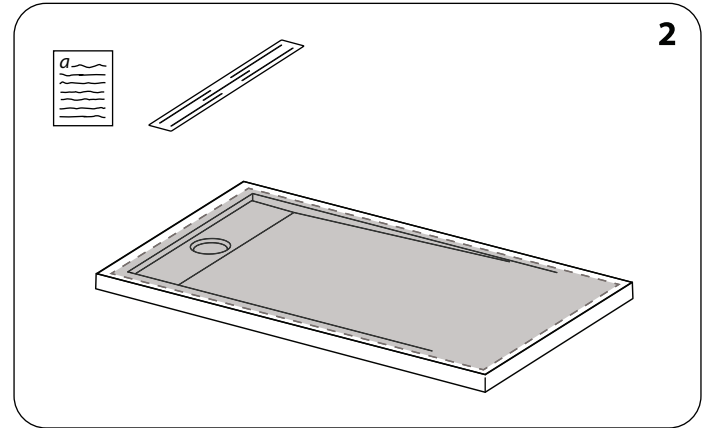
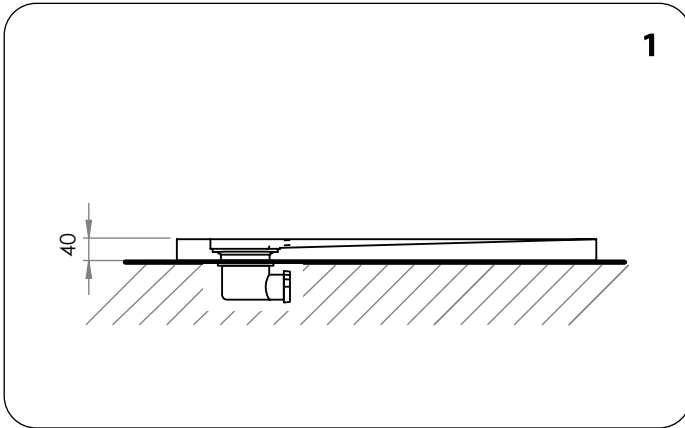

**FR** Veuillez vérifier à la livraison que le receveur correspond bien à votre commande, qu'il ne présente aucun défaut, rayure, choc, etc. et est en parfait état pour procéder à l'installation. Pour le nettoyage utilisez des savons liquides, de l'eau et une éponge ou un chiffon non-abrasif.

**EN** Please check immediately that delivered shower tray is in conformity with your order, doesn't have any imperfection, scratch, impact, etc. and is in perfect conditions for installation. Use for cleaning liquid soap, water and non-abrasive sponge or rag.

**ES** Al recibir el producto verifique que corresponde con su pedido y que no haya sufrido ningún tipo de desperfecto, arañazo, golpe, etc. y se encuentra en perfecto estado para su instalación. Para la limpieza utilice jabones líquidos, agua y paños o esponjas no abrasivos.

**DE** Bitte prüfen sie sofort die gelieferte brausetasse, ob diese Ihrer bestellung entspricht, sie keinerlei schäden wie abschürfungen, risse, cut´s oder sonstige beschädigungen aufweist und diese sich in einem ordnungsgemäßen zustand für einen einbau befindet. Bitte benützen sie zur reinigung flüssige seife, wasser und KEINE scheuernden mittel oder Schwämme.

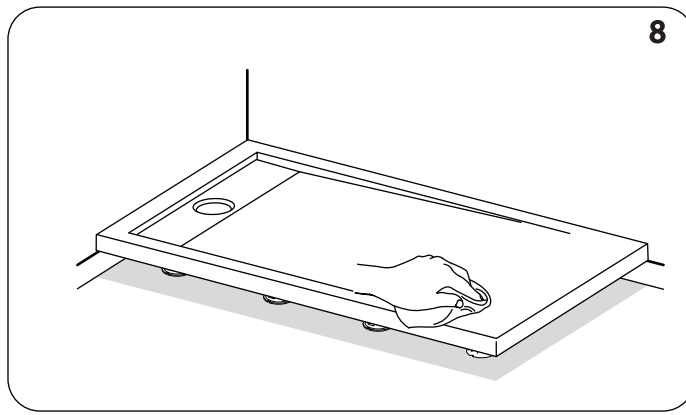
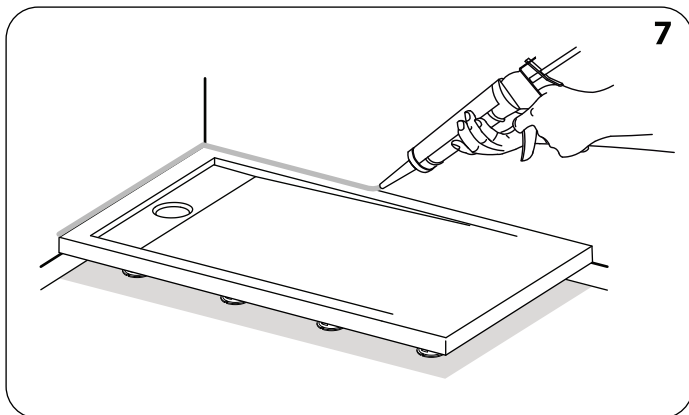
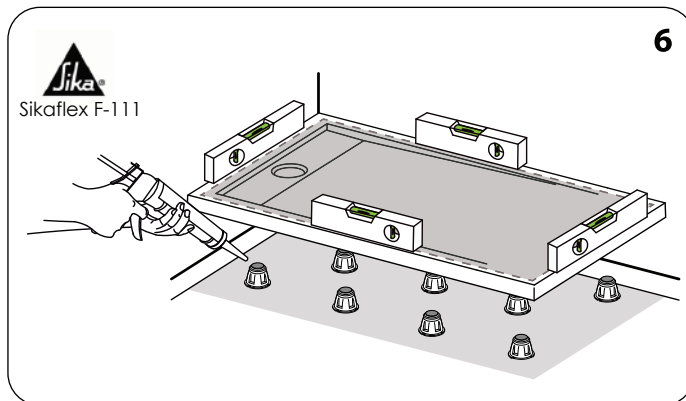
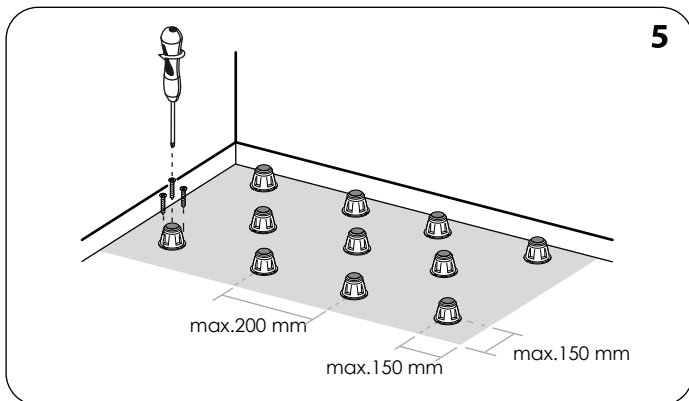
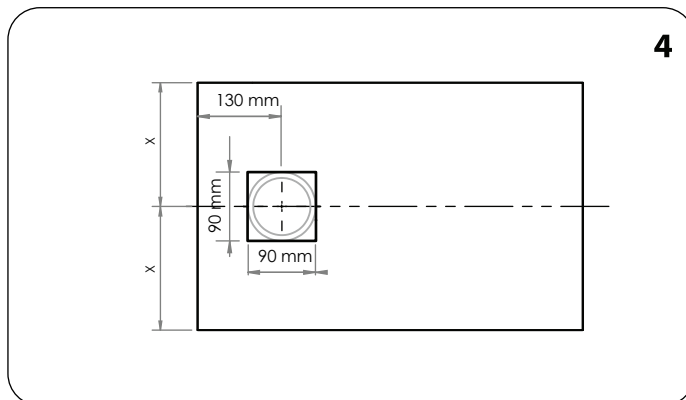
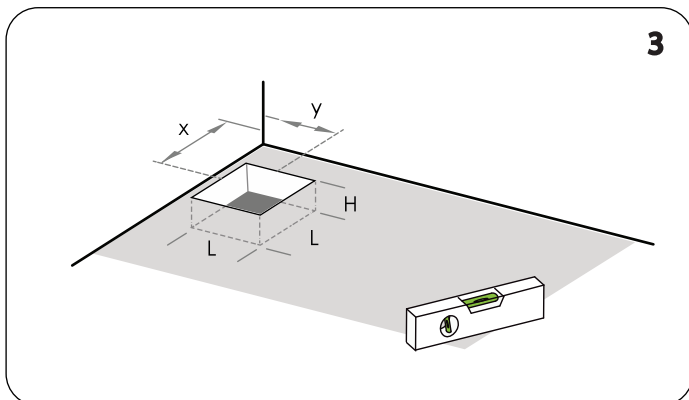
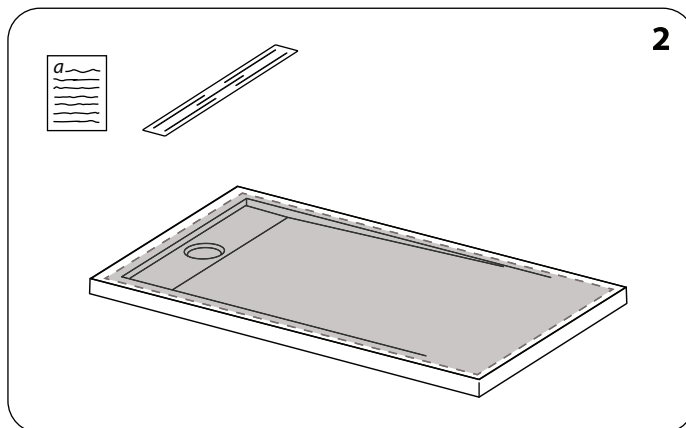
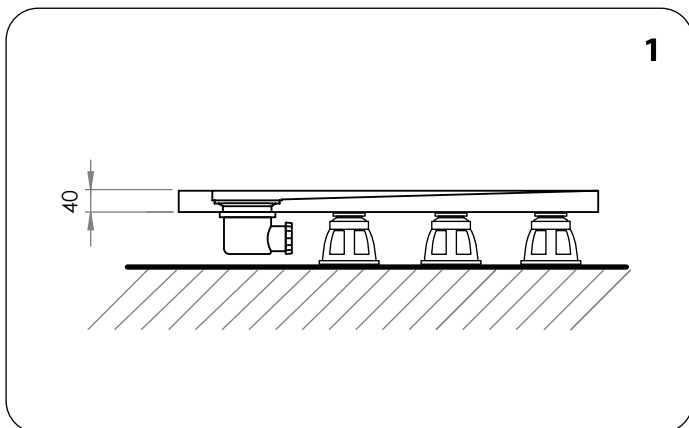

**FR** Veuillez vérifier à la livraison que le receveur correspond bien à votre commande, qu'il ne présente aucun défaut, rayure, choc, etc. et est en parfait état pour procéder à l'installation. Pour le nettoyage utilisez des savons liquides, de l'eau et une éponge ou un chiffon non-abrasif.

**EN** Please check immediately that delivered shower tray is in conformity with your order, doesn't have any imperfection, scratch, impact, etc. and is in perfect conditions for installation. Use for cleaning liquid soap, water and non-abrasive sponge or rag.

**ES** Al recibir el producto verifique que corresponde con su pedido y que no haya sufrido ningún tipo de desperfecto, arañazo, golpe, etc. y se encuentra en perfecto estado para su instalación. Para la limpieza utilice jabones líquidos, agua y paños o esponjas no abrasivos.

**DE** Bitte prüfen sie sofort die gelieferte brausetasse, ob diese Ihrer bestellung entspricht, sie keinerlei schäden wie abschürfungen, risse, cut´s oder sonstige beschädigungen aufweist und diese sich in einem ordnungsgemäßen zustand für einen einbau befindet. Bitte benützen sie zur reinigung flüssige seife, wasser und KEINE scheuernden mittel oder Schwämme.

ANCHO / LARGEUR / WIDTH 700 mm

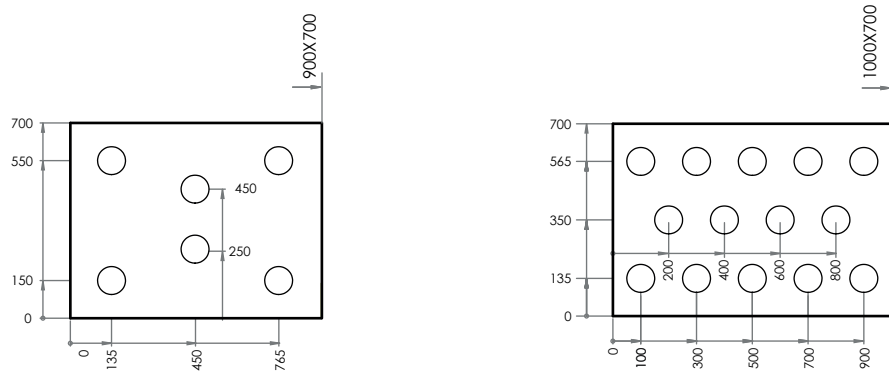

ANCHO / LARGEUR / WIDTH 800 mm

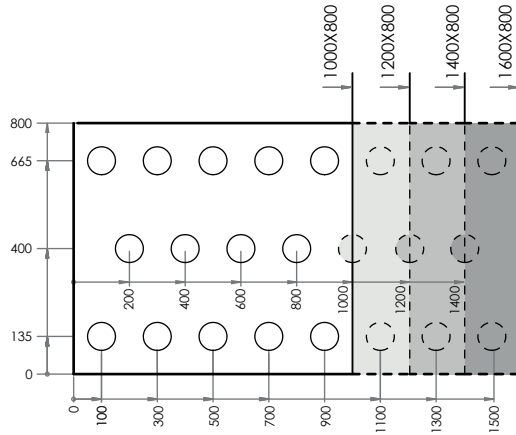

ANCHO / LARGEUR / WIDTH 900 mm

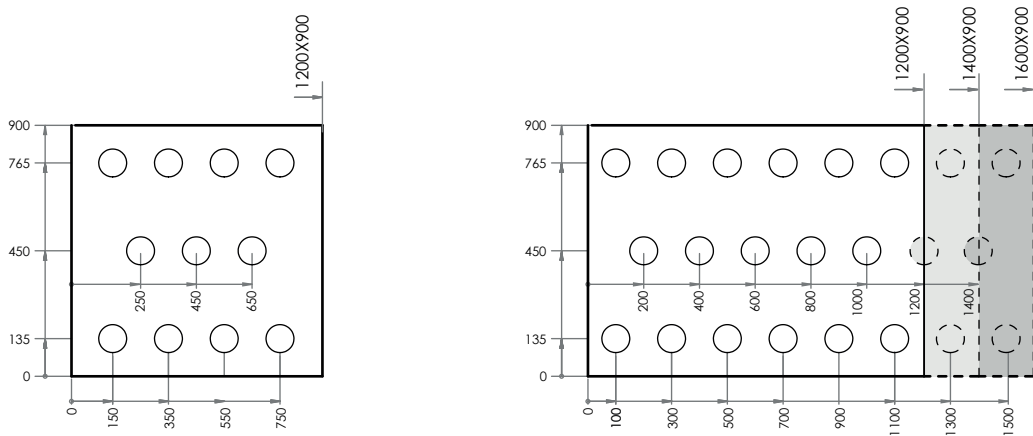

ANCHO / LARGEUR / WIDTH 1000 mm

